



Tracer™ ORP PockeTester

Code 1742



Water Testing Leader Since 1919!

TRACER™
ORP POCKETESTER • CODE 1742

Introduction	4
Specifications	4
Contents	5
Parts & Accessories	6
Meter Description	
Front Panel Description	5
TRACER Display	5
Basic Operation	
Powering the TRACER	6
Electrode Recognition	6
Automatic Calibration	6
Data Hold	6
ORP Testing	
Overview	6
ORP Display	6
Getting Started	6
ORP Measurement	6
Storing Readings	7
Recalling Stored Readings	7
Maintenance	
Storage	8
Battery Replacement	8
Troubleshooting	9
Replacing the Electrode	9
Expand Your TRACER	10
Warranty	11

INTRODUCTION

Congratulations on your purchase of the TRACER ORP PocketTester. The advantages of the TRACER to the user include: Easy to use and maintain, high accuracy, automatic calibration, and fast response. The TRACER has a 15-reading memory storage. Careful use and maintenance will provide years of reliable service.

SPECIFICATIONS

<i>Display</i>	<i>Multifunction display with bar graph</i>
<i>Operating conditions</i>	<i>32 to 122°F (0 to 50°C) and < 80% RH</i>
<i>ORP Range Accuracy</i>	<i>± 999mV/ ±4mV</i>
<i>Measurement storage</i>	<i>15 readings (numbered) readings</i>
<i>Low battery indicator</i>	<i>'BAT' appears on the LCD</i>
<i>Power</i>	<i>Four CR 2032 button batteries (see page 6)</i>
<i>Auto power off</i>	<i>After 10 minutes of inactivity</i>

CONTENTS

ORP TRACER PocketTester Kit, ±999mV Range *Code 1742*

Includes:

Sample Cup w/cap†

† not sold individually. See below.

PARTS & ACCESSORIES

<i>ORP Replacement Electrode</i>	<i>Code 1734</i>
<i>Weighted Stand w/Sample Cups (5)</i>	<i>Code 1746</i>
<i>Sample Cups w/caps (24)</i>	<i>Code 1745</i>

METER DESCRIPTION

Front Panel Description

1. Battery compartment cover
2. LCD Display
3. MODE/HOLD button
4. CAL/RECALL button
5. ON/OFF button
6. Electrode Collar
7. Electrode Sensor
(Note: The Electrode storage cap is not shown)



LCD Display

1. Reading
2. Units
3. Bargraph
4. Data Hold
5. Scale
6. Low Battery

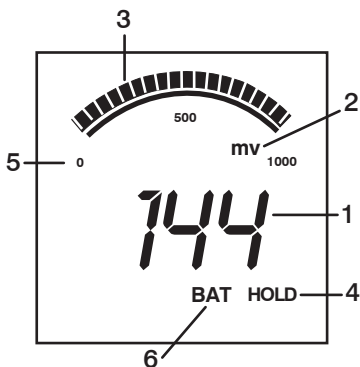

BASIC OPERATION

Powering the TRACER

If the batteries are weak, the BAT indicator will appear on the LCD. Press the ON/OFF key to turn the TRACER on or off. The auto power off feature will shut the TRACER off automatically after 10 minutes of inactivity.

Electrode Recognition

When the TRACER is turned on, it will recognize the type of electrode that is connected and will display the appropriate unit of measure. An electrode must be attached before turning the meter on.

Automatic Calibration

When the TRACER is turned on, it will enter the Automatic Calibration mode. 'SELF' and 'CAL' will appear on the display while calibration is in progress. After the calibration is completed, the 'SELF' and 'CAL' display icons will extinguish and both the main display and the bargraph will read ORP in mV.

Data Hold

Press the MODE/HOLD button to freeze the current reading. The HOLD display icon will appear along with the held reading. The held reading will be stored in the next 15-reading storage location. Press the MODE/HOLD button to return to normal operation.

TESTING

Overview

ORP is the abbreviation for Oxidation Reduction Potential and represents the oxidizing or reducing nature of a solution. The overall reactive tendency of a solution can be determined from ORP measurements.

ORP Display

When the electrode is placed in a solution, the main display and bar graph will indicate the ORP reading. Readings flash until they have stabilized. The bar graph is 'center zero', i.e. at 500mV there is no display. As the readings increase from 0 to 1000 mV the bar will move from the left to the right.

Getting Started

1. Remove the cap from the bottom of the TRACER to expose the flat surface electrode and reference junction.
2. White KCL crystals may be present in the cap. Rinse the crystals with tap water.

ORP Measurement

1. Press the ON/OFF button to turn the meter on. Place the electrode ½” to 1” into the test sample .
2. Stir once and let the reading stabilize for 1 to 3 minutes. The main display will indicate the ORP in numeric units from 0 to 1000mV. The bar graph will also display the ORP value. As the ORP increases, the bar graph will move from left to right.
3. Press the ON/OFF button to turn the meter off. Rinse the electrode with distilled water. Do not use deionized water. Replace cap.

Storing Readings

4. After the reading is made press the MODE/HOLD button to store the current reading. The HOLD icon will be displayed. The storage location number will also be displayed followed by the reading being stored. (Fig. 1)
5. Press the MODE/HOLD button to return to normal operation.
6. Repeat step 1 to store the next reading.
7. If an attempt is made to store more than 15 readings, the stored readings (starting with the first reading) will be overwritten.

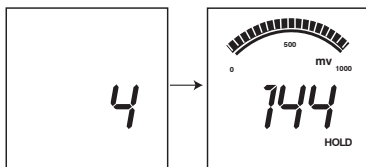

Fig. 1

Recalling Stored Readings

NOTE: First ensure that the HOLD symbol is not displayed. If it is, exit the HOLD function by pressing the MODE/HOLD button.

1. Press the CAL/RECALL button once and then press the MODE button immediately after CAL is displayed; the location number (1 through 15) will flash. If the CAL mode is accidentally accessed (display flashing), press the CAL/RECALL button again to exit.
2. The last stored reading taken will be displayed first. To advance through the stored readings, press the MODE/HOLD button. The location number is displayed first, followed by the reading stored in that location.
3. To exit the recall mode, press the CAL/RECALL button and the TRACER will return to normal operation.
4. If the batteries are removed, any stored readings will be discarded.

MAINTENANCE

Storage

To preserve electrode life keep the sponge in the protective cap soaked with distilled water or tap water. Do not use deionized water. Do not allow electrode to dry out. Cap TRACER when not in use. Store vertically.

Battery Replacement

1. Twist off the battery compartment cap.
2. Hold the battery housing in place with one finger. Remove the battery carrier by pulling on the small tabs.
3. Replace the four CR2032 batteries. Observe polarity.
4. Replace the battery compartment cap.

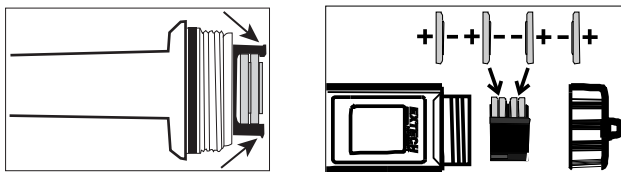

NOTE: If the batteries are removed, stored data will be cleared. Factory calibrations will be retained.

TROUBLESHOOTING

Problem	Cause	Action
Power on but no display	Batteries	Insert batteries
	Batteries	Verify correct polarity
	Batteries	Replace batteries
Unstable readings	Electrode	Immerse electrode more deeply in sample
	Electrode	Condition electrode before first use. Soak in tap water for 10 minutes.
	Electrode	Remove air bubbles caught under electrode
	Electrode	Clean electrode
	Electrode	Replace electrode
Static charge	Wiping electrode	Rinse electrode and blot. Do not wipe electrode
Same readings in different samples	Cracked or broken electrode	Replace electrode. Avoid plunging electrode into bottom of container and stir bars.
Display frozen	HOLD function	Press MODE or turn meter off
	Button response	Remove batteries (stored data will be lost)
Steady “-1 ” display	Wait	Reading not stable yet

REPLACING THE ELECTRODE

The TRACER is shipped with an electrode attached. If the electrode needs to be replaced, follow these steps for removing and connecting electrodes.

1. Turn meter off.
2. To remove the electrode, turn the collar counter-clockwise and remove it.
3. Gently rock the electrode from side to side, pulling it downwards, until it disconnects from the meter.
4. To attach an electrode, carefully plug the electrode into the meter socket. CAUTION: Take care to align the pins carefully. Bent or broken pins will cause the meter to malfunction.
5. Tighten the electrode collar firmly enough to make a good seal. A rubber gasket will seal the electrode with the meter.

EXPAND YOUR TRACER

Interchangeable electrodes are available to convert the ORP TRACER to a Total Chlorine TRACER or a pH TRACER.

Remember to ask for instructions and appropriate reagent or buffer tablets when ordering Total Chlorine or pH electrodes.

Total Chlorine TRACER Electrode, 0.00-10.00 ppm The Total Chlorine TRACER Electrode (Code 1732) requires the use of TRACER TCL Tablets. Order Code 7044A-J (100 pack).	Code 1732
pH TRACER Electrode, 0.00 - 14.00 pH The pH TRACER Electrode is used with pH 4.0, 7.0 and 10.0 buffers. Order using the following codes:	Code 1733
pH 4.0 Mini Buffer Tablets (100)	Code 3983A-J
pH 7.0 Mini Buffer Tablets (100)	Code 3984A-J
pH 10.0 Mini Buffer Tablets (100)	Code 3985A-J

WARRANTY INFORMATION

LaMotte Company warrants this instrument to be free of defects in parts and workmanship for 1 year from the date of shipment and this probe be free of defects in parts and workmanship for 6 months from the date of shipment. If it should become necessary to return the instrument for service during or beyond the warranty period, contact our Technical Service Department at 1-800-344-3100 or tech@lamotte.com for a return authorization number or visit www.lamotte.com for troubleshooting help. The sender is responsible for shipping charges, freight, insurance and proper packaging to prevent damage in transit. This warranty does not apply to defects resulting from action of the user such as misuse, improper wiring, operation outside of specification, improper maintenance or repair, or unauthorized modification. LaMotte Company specifically disclaims any implied warranties or merchantability or fitness for a specific purpose and will not be liable for any direct, indirect, incidental or consequential damages. LaMotte Company's total liability is limited to repair or replacement of the product. The warranty set forth above is inclusive and no other warranty, whether written or oral, is expressed or implied.

LaMOTTE COMPANY

Helping People Solve Analytical Challenges

PO Box 329 • Chestertown • Maryland • 21620 • USA
800-344-3100 • 410-778-3100 (Outside USA) • Fax 410-778-6394
Visit us on the web at www.lamotte.com